

..puraclenz®

Photon™

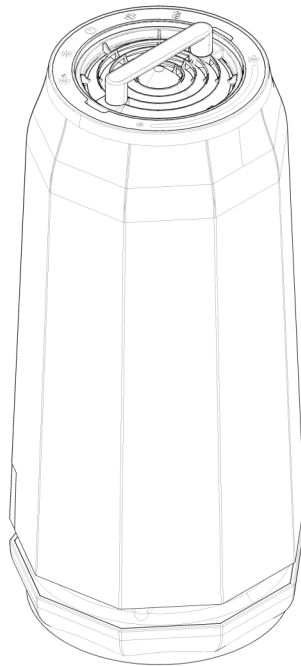

USER GUIDE

Scan the QR code with your smart phone or visit the URL below to access product registration, usage tips, and more.

puraclenz.com/GetStartedP3000X



For support:

In the USA: Contact us at 1-833-360-PURA or Support@puraclenz.com
In Canada: Contact us at 855-900-8822 or Support@ogenasolutions.com

READ AND SAVE THESE INSTRUCTIONS

(Version P3000X-US001)

Important Safety Instructions

BEFORE USING THIS MACHINE READ ALL INSTRUCTIONS AND CAUTIONARY MARKINGS IN THIS USER GUIDE AND ON THE MACHINE.

When using an electrical machine, basic precautions should always be followed including the following:

WARNING: These warnings apply to the machine, and where applicable, to all accessories, lamps, filters, or main adapters.

TO REDUCE THE RISK OF FIRE, ELECTRICAL SHOCK, OR INJURY:

These warnings apply to the machine, and where applicable, to all accessories, lamps, filters, or main adapters.

1. This appliance can be used by children aged from 8 years and above and persons with reduced physical, sensory, or mental capabilities or lack of experience and knowledge if they have been given supervision or instruction concerning use of the appliance in a safe way and understand the hazards involved. Children shall not play with the appliance. Cleaning and user maintenance shall not be made by children without supervision.
 2. Ensure device is fully assembled in line with the instructions before use. Do not dismantle the machine by removing any screws, clasps, or other disassembly not shown in this manual. Disassembly may void the product warranty.
 3. Do not allow to be used as a toy. Close attention is necessary when used by or near children. Children should be supervised to ensure that they do not play with the device.
 4. Use only as described in this User Manual. Do not carry out any maintenance other than that shown in this manual or advised by Puraclenz® Product Support.
 5. Suitable for dry location ONLY. Do not use outdoors. Do not expose to water or rain.
 6. Do not handle any part of the plug or machine with wet hands.
 7. Do not operate any machine with a damaged cord or plug. Discard the machine or return to an authorized service facility for examination and/or repair. If the supply cord is damaged it must be replaced by Puraclenz®, its service agent, or similarly qualified person to avoid injury.
 8. If the machine is not working as it should, has received a sharp blow, has been dropped, damaged, left outdoors, or dropped into water, do not use the device and contact the Puraclenz® Helpline.
 9. Do not stretch the cord or place the cord under strain. Keep cord away from heated surfaces.
 10. Do not run cord under carpeting. Do not cover cord with throw rugs, runners or similar coverings. Do not route cord under furniture or appliances. Arrange cord away from traffic area and where it will not be tripped over.
 11. Do not unplug by pulling on the cord. To unplug, grasp the plug, not the cord. The use of an extension cord is not recommended.
 12. Do not put any object into openings or the inlet grill. Do not use with any opening blocked; keep free of dust, lint, hair, and anything that may reduce airflow.
 13. Clean the machine with a damp cloth only. Do not use any cleaning agents or lubricants on this machine. Unplug before cleaning or carrying out any maintenance. Do not let water or any other liquid or flammable detergent enter the appliance to avoid electric shock and/or a fire hazard.
 14. Always carry the machine by the base, do not carry it by the Top Cover handle.
 15. Unplug from outlet when not in use for extended periods. To avoid a tripping hazard, safely coil the cord.
 16. Do not use near furnaces, fireplaces, stoves, or other high temperature heat sources.
 17. Do not use in conjunction with or directly next to an air freshener or similar products. Keep essential oils and chemicals away from the appliance.
 18. For cleaning and maintenance, please refer to "Maintenance Instructions" sections (page 6) in online user manual.
 19. Prior to cleaning or other maintenance, the appliance must be disconnected from the supply mains.
- Please leave 2 foot (30cm) free space above the air purifier.

CAUTION: Changes or modifications not expressly approved by Puraclenz® could void the product warranty.

WARNING: To reduce the risk of fire or electric shock, do not use this fan with any solid-state speed control device.

THIS MACHINE IS INTENDED FOR INDOOR USE ONLY.

NOTE: This equipment has been tested and found to comply with the limits for a Class B digital device, pursuant to Part 15 of the FCC Rules. These limits are designed to provide reasonable protection against harmful interference in a residential installation. This equipment generates, uses and can radiate radio frequency energy and, if not installed and used in accordance with the instructions, may cause harmful interference to radio communications. However, there is no guarantee that interference will not occur in a particular installation. If this equipment does cause harmful interference to radio or television reception, which can be determined by turning the equipment off and on, the user is encouraged to try to correct the interference by one or more of the following measures:

- Reorient or relocate the receiving antenna.
 - Increase the separation between the equipment and receiver.
 - Connect the equipment into an outlet on a circuit different from that to which the receiver is connected.
- Consult the dealer or an experienced radio/TV technician for help.

This device complies with Part 15 of the FCC Rules. Operation is subject to the following two conditions: (1) this device may not cause harmful interference, and (2) this device must accept any interference received, including interference that may cause undesired operation.

WARNING: Skin or eye damage may result from directly viewing the light produced by the lamps in the apparatus. Always disconnect power before servicing. Replace Recharge Cell™ with Puraclenz® Model#R0002.

In the Box

Top Cover



Recharge Cell™
(inside purifier)

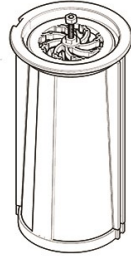

Pre-Filter
(inside purifier)

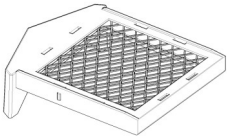

Purifier

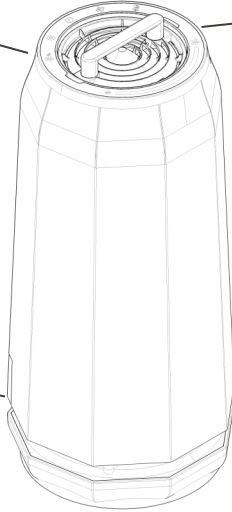

Optional Mounting Kit

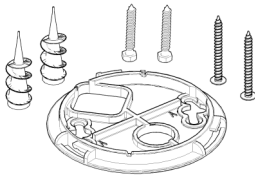

Extra Pre-Filter

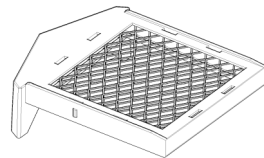

Quick Start Guide & User Manual



Operation and Placement

Instructions also available at puraclenz.com/GetStartedPhoton

For best results:

1. The Purifier unit should be placed in a central location and always be connected to electric power. Do not connect power cord to a switched outlet or automatic timer that can stop continuous use.
2. The Purifier unit is designed to operate 24/7 for continuous coverage. During normal operation you will hear the fan running and power light will be on.
3. Purifier will work as designed in typical indoor environments. For best results, we recommend keeping room temperature above 72°F (22°C), humidity between 40-70% relative humidity, and keep windows closed at all times.
4. In spaces with ceilings over 12 feet (3.6m), place your purifier unit no higher than 10 feet (3.0m) off the floor. Place purifier on a stable surface, such as a countertop or table; alternatively, it can be mounted on a wall or ceiling with included mounting kit (see page 5).

User Interface

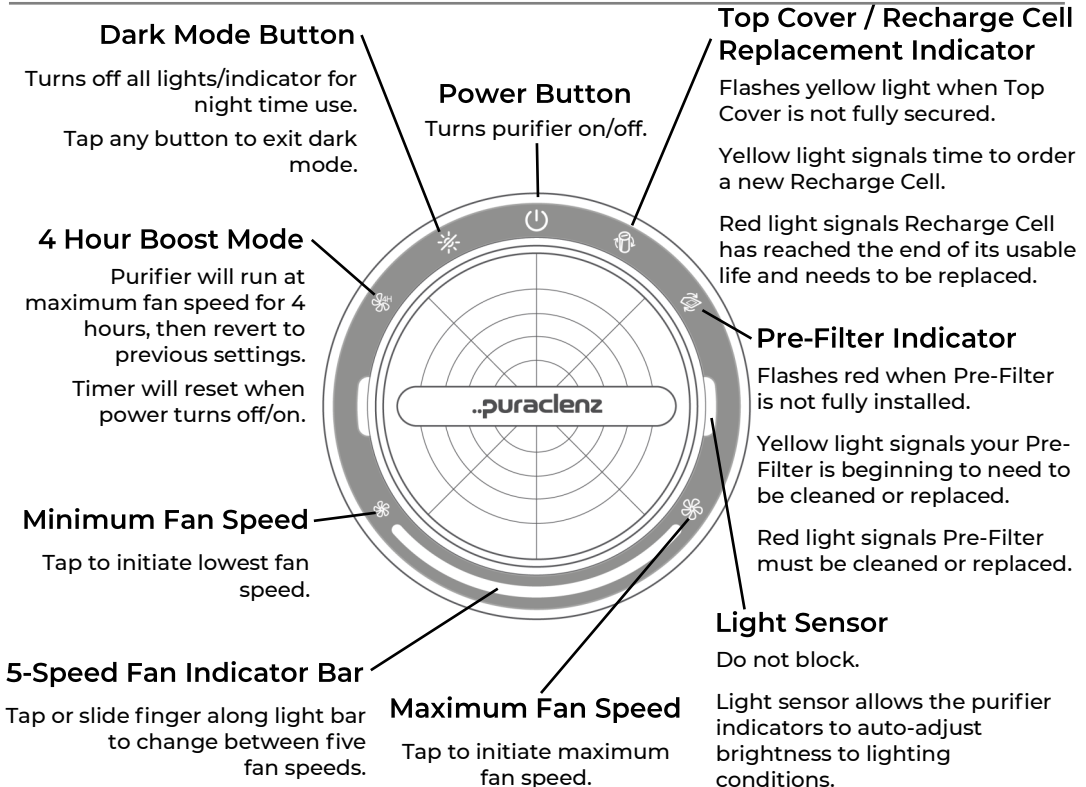

Installation Instructions

For ceiling or wall installations:

1. Pull the power cord connector through the rectangular hole in the mounting bracket (A). Secure the mounting bracket to the wall or ceiling using the screws positioned in the small ends of the keyholes before tightening the screws (B). See **Diagram 1**.
2. Install the Purifier unit on the mounting bracket (A) and rotate Purifier unit in the counter clockwise direction (B) until you hear an audible click sound. See **Diagram 3**.
3. If an electrical outlet is not available or cannot be used: Unplug the power cord from the Purifier unit and have a certified electrician perform the connection.
4. For drop ceiling installation: Always have a certified electrician perform the installation by securely attaching mounting bracket to drop-tile ceiling rail.

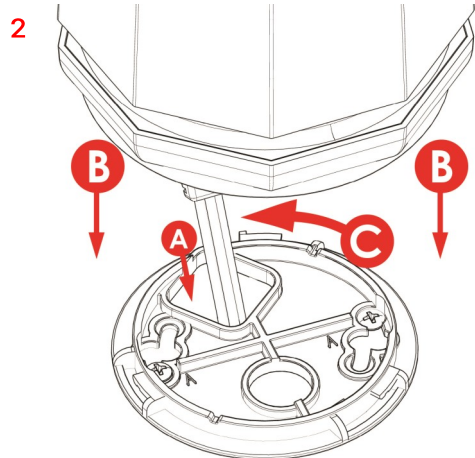
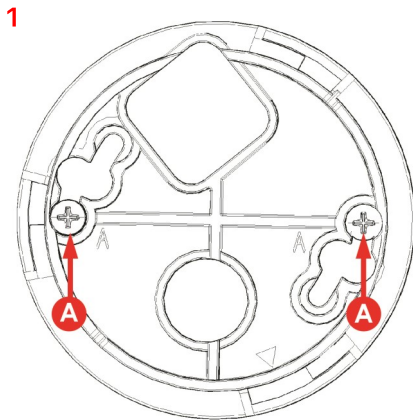

For table top installations:

1. Place Purifier unit in desired installation location.
2. Plug into electrical outlet, turn the Purifier on by pressing the Power Button, and Purifier unit will automatically start purifying.

Maintenance Instructions

Change Pre-Filter

Puraclenz recommends changing or cleaning the Pre-Filter every 6-7 months, or sooner if air is particularly dusty.

1. Slide out the old filter and discard. See **Diagram 1**.
2. Slide in new Pre-Filter Model#R0001 to automatically resume normal operation. See **Diagram 2**.
3. Hold down the Pre-Filter Icon  for five seconds to reset the timer.

SCAN for
Change Pre-Filter
Video Instructions

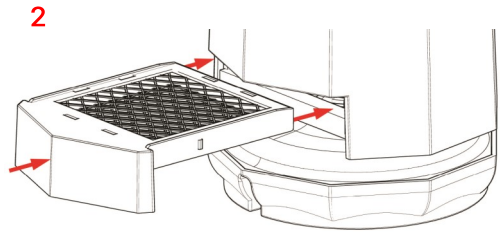
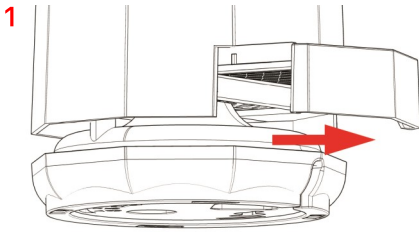

Wash Pre-Filter

For best results, it is recommended to always to use a brand new Pre-Filter.

1. Slide out the dirty filter and set aside. See **Diagram 1**.
2. Slide in new or clean Pre-Filter Model#R0001 to automatically resume normal operation. See **Diagram 2**.
3. Spray water into dirty Pre-Filter to clean off all debris. See **Diagram 3**.
4. Shake excess water off Pre-Filter and let it dry overnight. Never install a wet Pre-Filter into the Purifier unit. See **Diagram 4**.

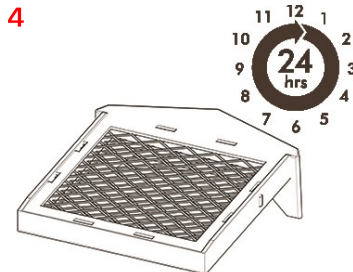
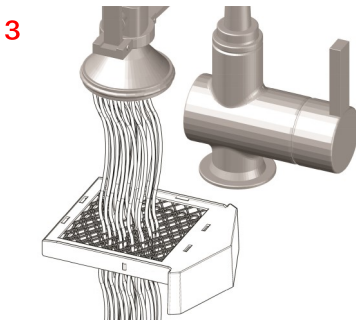

Maintenance Instructions

Replacing Recharge Cell

SCAN for Recharge Cell Replacement Video Instructions



Disconnect power before doing any work to your Purifier unit.

1. Turn Top Cover counterclockwise (A) and remove (B).
Note: if your Purifier unit is ceiling or wall mounted, be careful not to allow the Cell to fall out when removing the Top Cover.
2. Use your fingers or pliers to slide out old Recharge Cell from Purifier unit and discard.
3. Remove Red Caps from bottom and top of new Recharge Cell (Model#R0002).
4. Slide in new Recharge Cell into Purifier unit by aligning keyholes.
5. Align the Top Cover with Puraclenz® logo 30° counterclockwise to the front of the Purifier unit as highlighted in **Diagram 5**. Then place the Top Cover into Purifier as highlighted in **Diagram 6 (A)**. Twist the Top Cover clockwise (B) until you hear an audible click from the safety latch (highlighted) to automatically resume operation.
6. Hold down the Recharge Cell Icon  for five seconds to reset the timer.

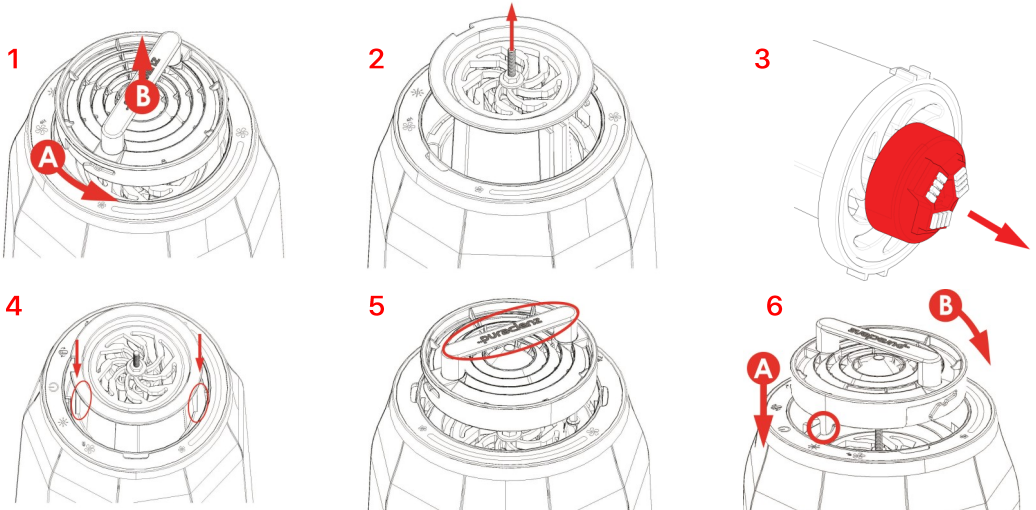

WARNING: Skin or eye damage may result from directly viewing the light produced by the lamps in the Recharge Cell apparatus. Always disconnect power before relamping or servicing. Replace Recharge Cell with Puraclenz® Model#R0002.

IMPORTANT: To prevent injury or damage for all ceiling and wall installations, when removing Top Cover take care not to allow Recharge Cell to fall out.

Troubleshooting

Normal Operation



Power Icon On

This shows your Purifier unit is working correctly.

All Lights Off

1. The lights on the purifier auto-dim to match the light in the room. Clean the Light Sensor to ensure it is not blocked.
2. If the fan is running, the unit may have been set into Dark Mode. Press any button to exit Dark Mode.
3. Press the Power Button to turn your purifier on.
4. Check the cord and outlet to ensure the unit has power.

All Lights Off

Order New Recharge Cell



Yellow Recharge Cell Indicator On

This indicates your Purifier unit has reduced operation and you need to replace your Recharge Cell. Order a new model #R0002. If your Cell is still under warranty, contact Puraclenz support.

Replace Recharge Cell



Red Recharge Cell Indicator On

This shows that your Purifier unit has operated for long enough that the Recharge Cell must be replaced. Follow instructions to replace your Recharge Cell on page 7. Once you have replaced your Recharge Cell, hold this button down for five seconds to reset the Recharge Cell monitor.

Top Cover Open



Yellow Recharge Cell Indicator Flashing

Twist your Top Cover firmly in the clockwise direction until you hear an audible click sound. See Diagram 5 on page 7.

Clean Pre-Filter



Yellow or Red Pre-Filter Indicator On

This indicates your Pre-Filter is dirty. Order a new #R0001 Pre-Filter, or clean your existing Pre-Filter by following instructions on page 6. Once you have cleaned your Pre-Filter, hold this button down for five seconds to reset the Pre-Filter monitor.

Pre-Filter Out



Yellow Pre-Filter Indicator Flashing

This indicates your Pre-Filter is not inserted fully. Remove and reinsert your Pre-Filter by following instructions on page 6. You should hear an audible click when the Pre-Filter is inserted correctly.

Puraclenz LLC, P.O. Box 733, Old Greenwich, CT 06870

PURACLENZ® is a registered trademark, and PHOTON and RECHARGE CELL are trademarks pending registration, all owned by Puraclenz LLC. All rights reserved © 2022, 2024.

For Patent Information go to: www.puraclenz.com/patents